

Parts List

Table with 4 columns: Ref, Var, IPN, Description. Lists various electronic components like capacitors and resistors with their part numbers and values.

Table with 4 columns: Ref, Var, IPN, Description. Continuation of the parts list, listing components like capacitors and resistors.

Table with 4 columns: Ref, Var, IPN, Description. Continuation of the parts list, listing components like capacitors and resistors.

TM9100 mobiles

Main Board (H5/H6)
25W
PCB Information



PCB IPN 220-01697-10

This document applies to the TM9100 main board (25W) for the following frequency bands:

- H5 = 400 to 470MHz
■ H6 = 450 to 530MHz

This document contains the following information:

- Parts List (H5 Mini-UHF Rev. 6, H5 BNC Rev. 1, H6 Mini-UHF Rev. 5, H6 BNC Rev. 1) Page 1
■ Grid Reference Index Page 5
■ PCB Layout – Top Side Page 7
■ PCB Layout – Bottom Side Page 8
■ Circuit Diagrams Page 9

The component values in the circuit diagrams are indicative only. Refer to the parts list for actual values used.

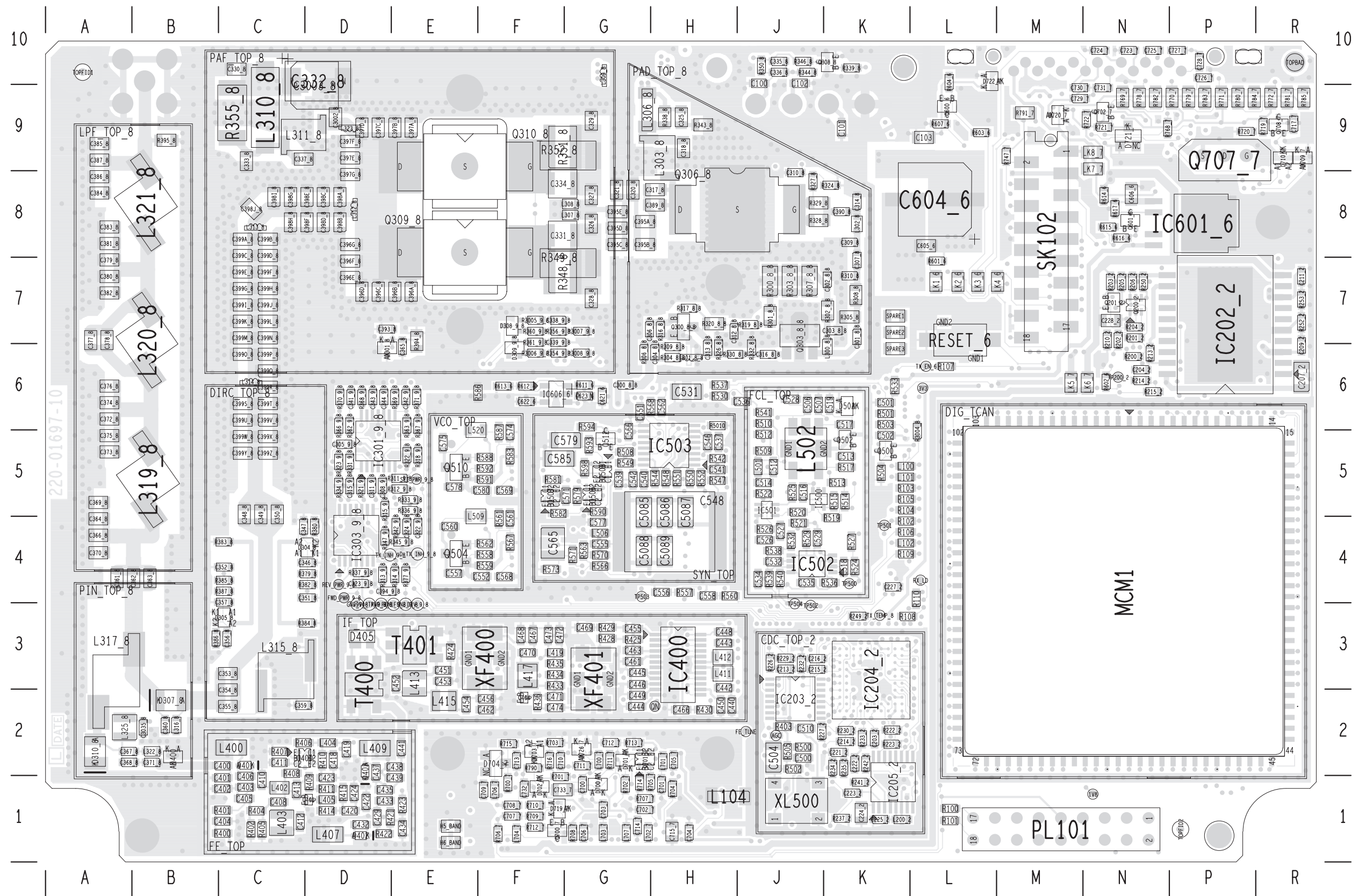

TAIT ELECTRONICS		IPN:	ISS:	DATE:	SCALE:
TM8000 TM8000 400-530MHz LAYOUT-PRIMARY-SIDE		220-01697-10	A	24Nov04	NTS

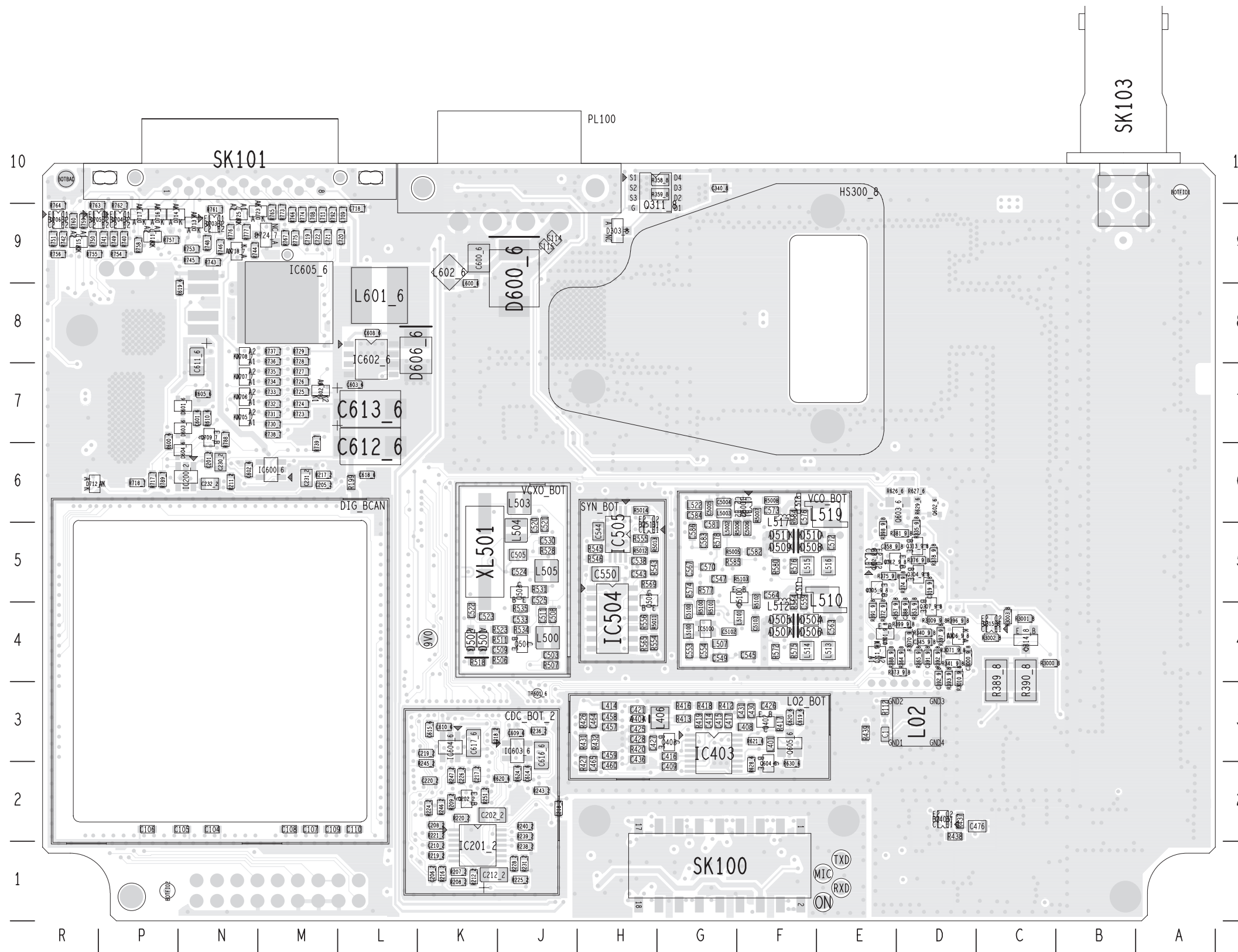

TAIT ELECTRONICS IPN: 220-01697-10 ISS: A DATE: 24Nov04 SCALE: NTS
TM8000 TM8000 400-530MHz LAYOUT-SECONDARY-SIDE

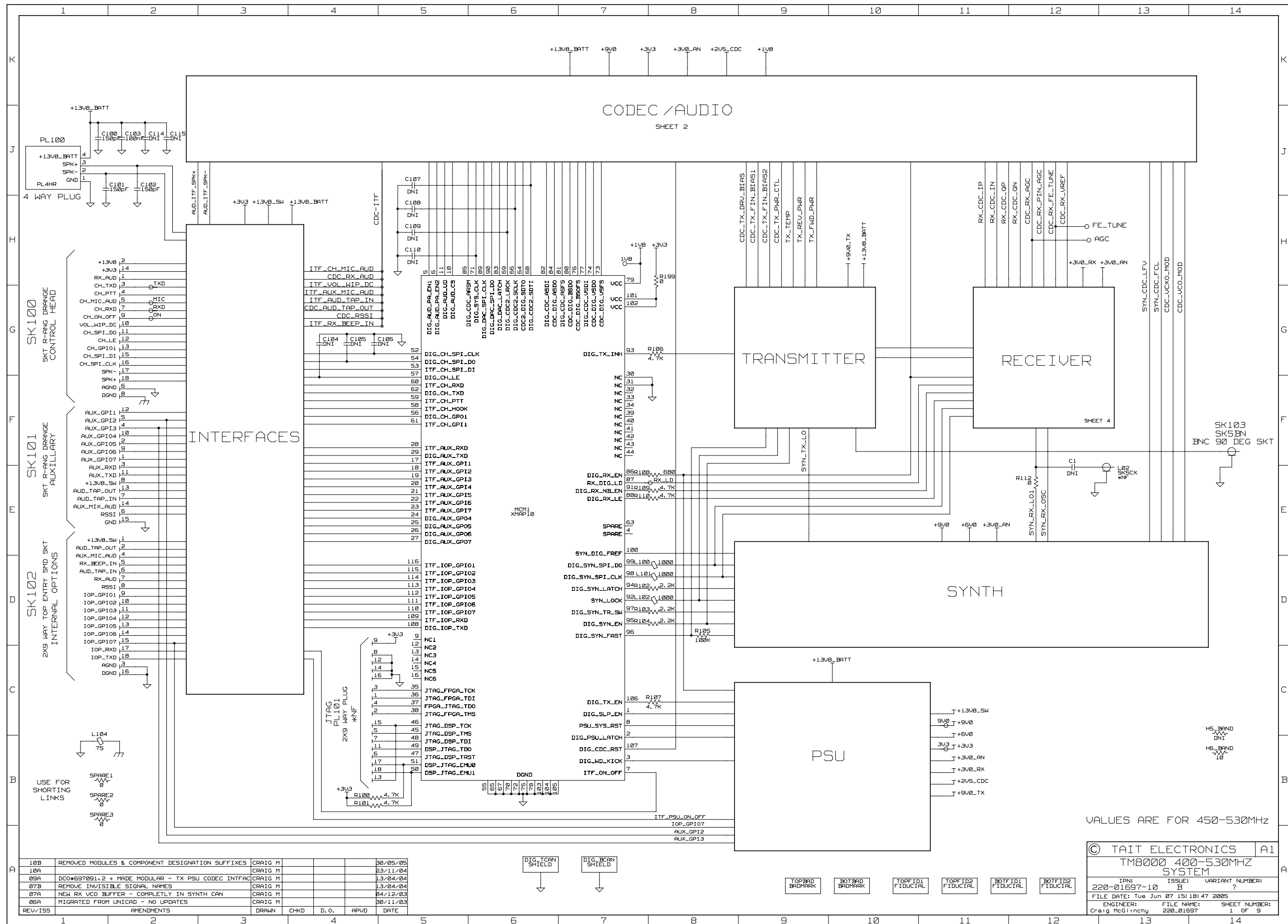

REV/ISS	AMENDMENTS	DRAWN	CHKD	D.O.	APUD	DATE
10B	REMOVED MODULES & COMPONENT DESIGNATION SUFFIXES	CRAIG M				30/05/05
10A		CRAIG M				23/11/04
09A	DC0#697091.2 + MADE MODULAR - TX PSU CODEC INTFAC	CRAIG M				13/04/04
07B	REMOVE INVISIBLE SIGNAL NAMES	CRAIG M				13/04/04
07A	NEW RX VCO BUFFER - COMPLETELY IN SYNTH CAN	CRAIG M				04/12/03
06A	MIGRATED FROM UNICAD - NO UPDATES	CRAIG M				30/11/03

© TAIT ELECTRONICS A1
 TM8000 400-530MHZ SYSTEM
 IPN: 220-01697-10 ISSUE: B VARIANT NUMBER: ?
 FILE DATE: Tue Jun 07 15:18:47 2005
 ENGINEER: Craig McGlinchy FILE NAME: 220.01697 SHEET NUMBER: 1 of 9

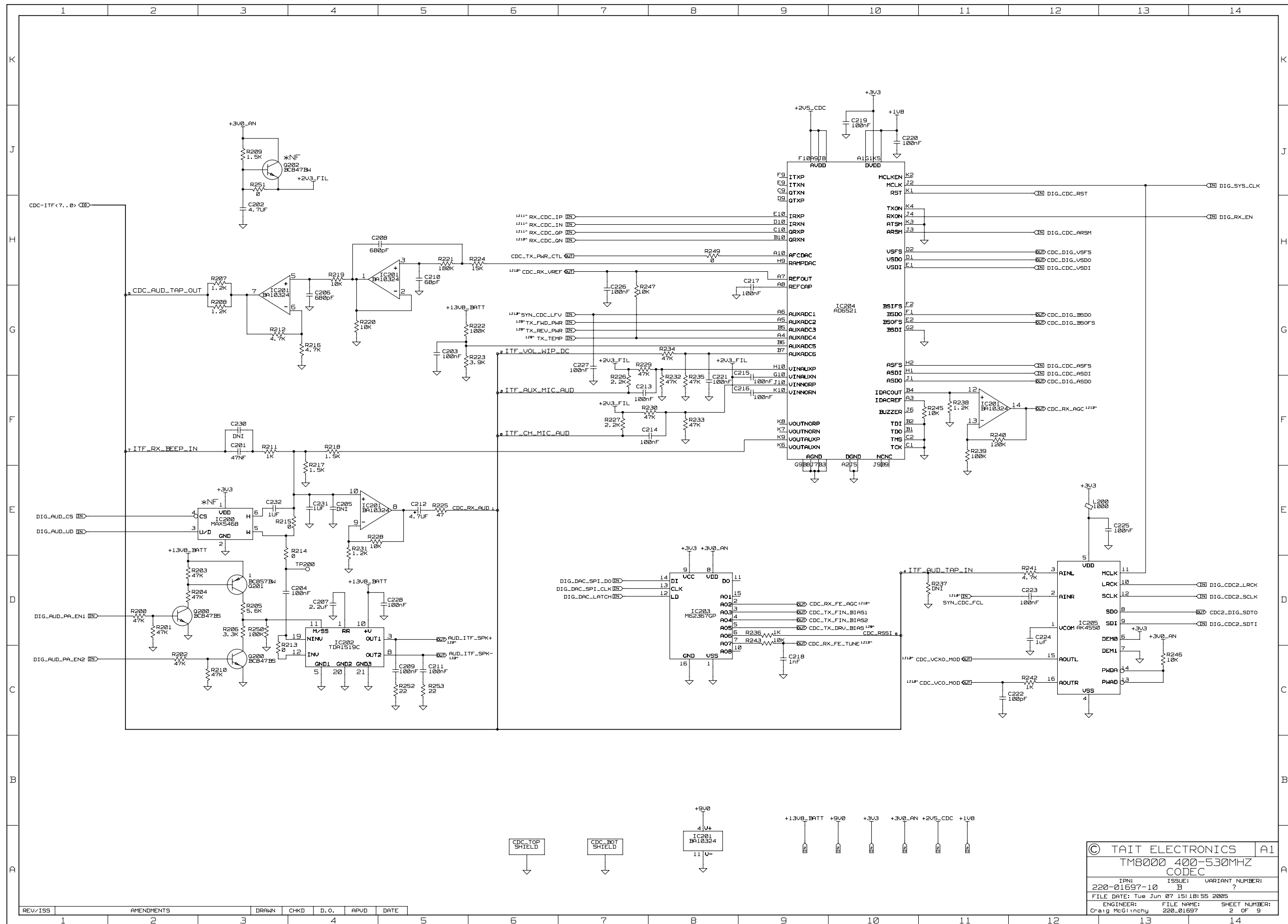

© TAIT ELECTRONICS A1
 TM8000 400-530MHZ
 CODEC
 IPN: 220-01697-10 ISSUE: B VARIANT NUMBER: 7
 FILE DATE: Tue Jun 07 15:18:55 2005
 ENGINEER: Craig McGlinchy FILE NAME: 220_01697 SHEET NUMBER: 2 OF 9

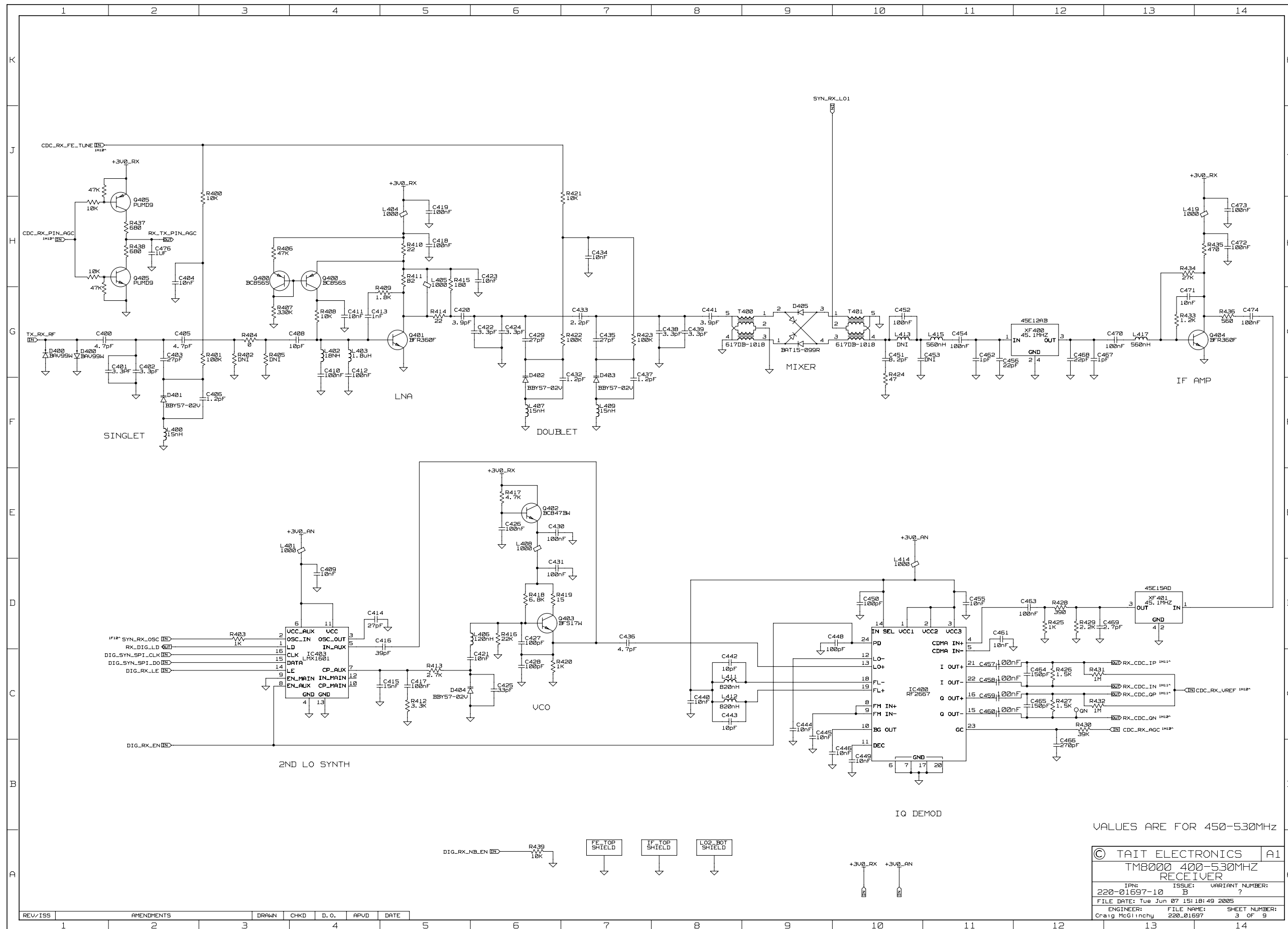

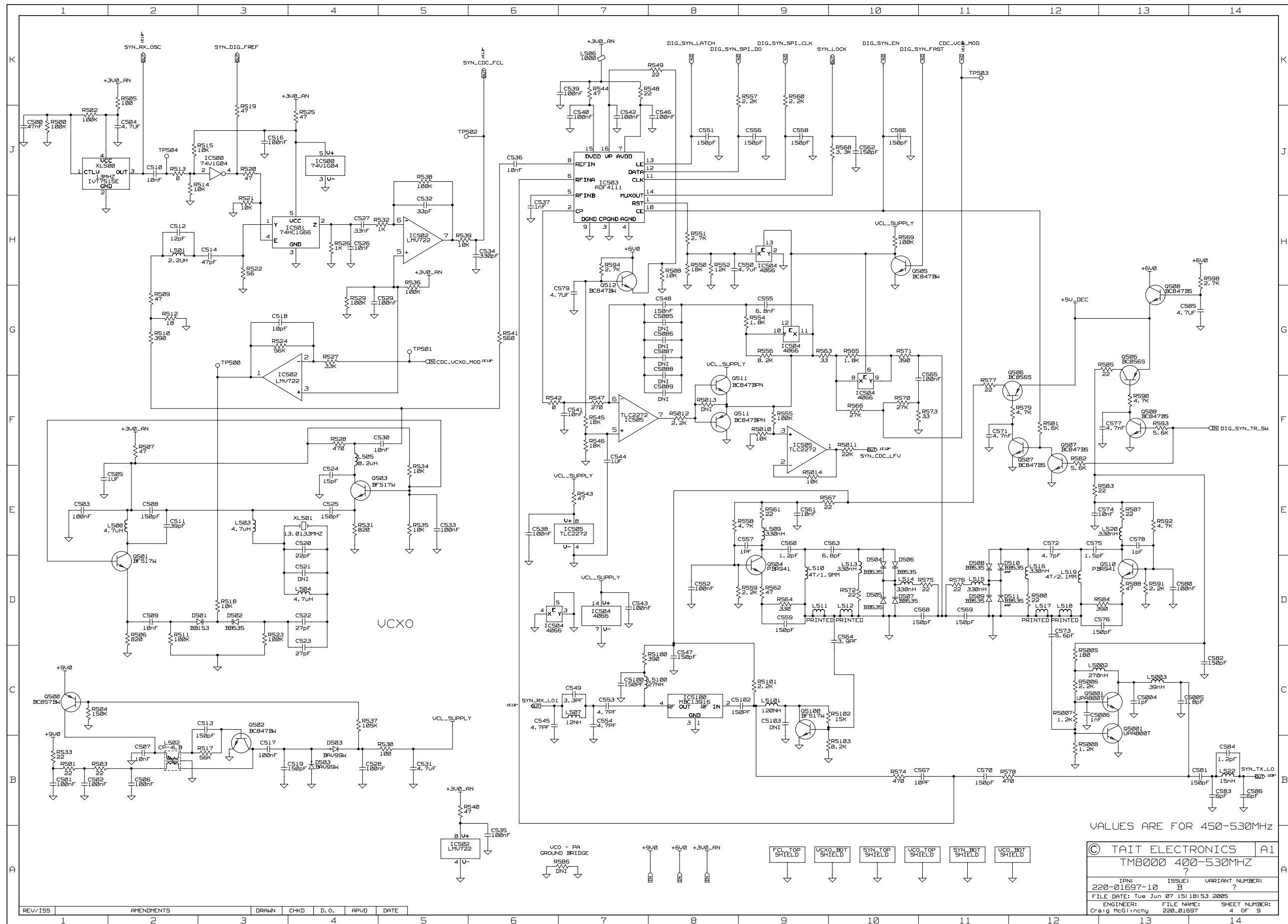

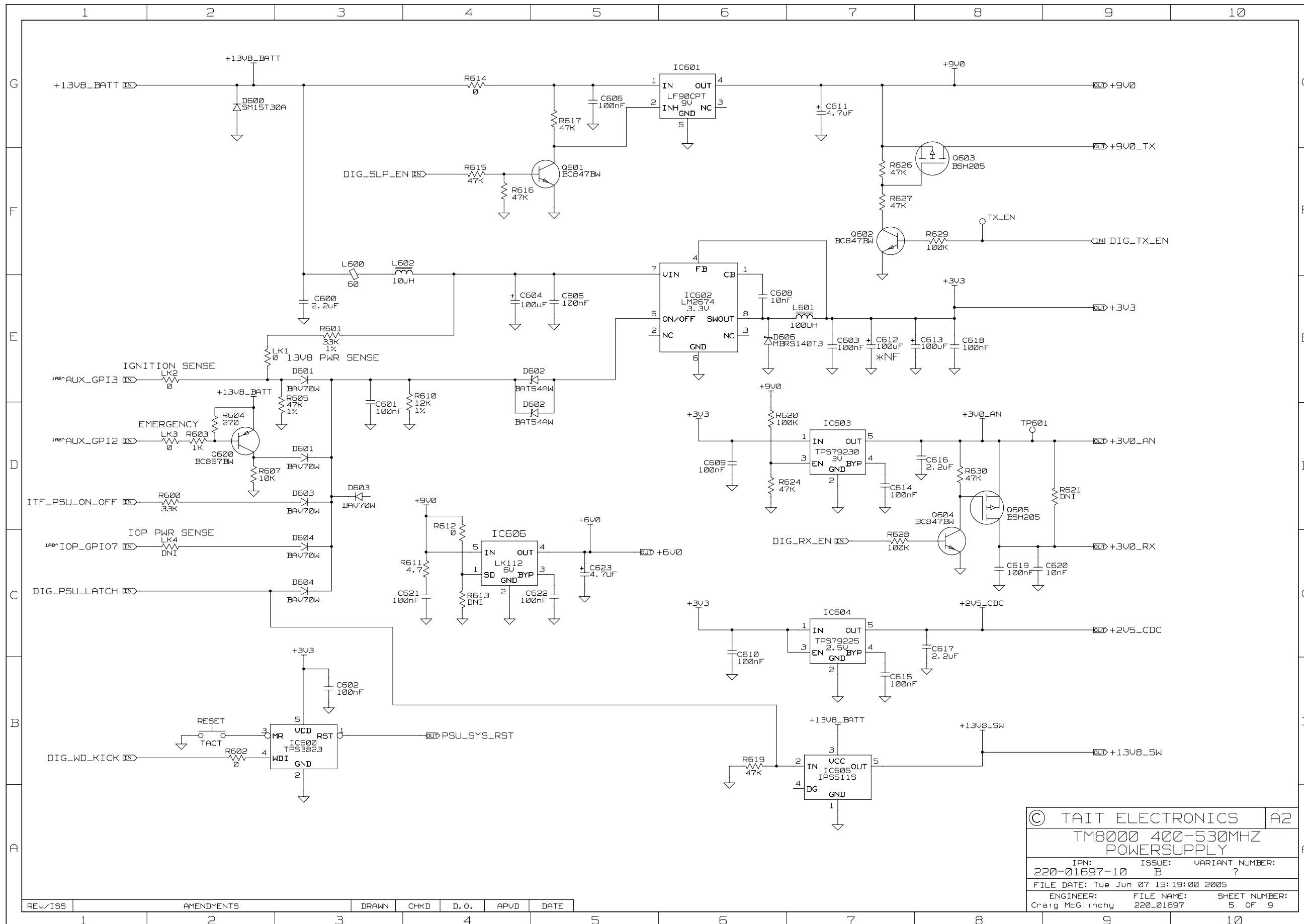

© TAIT ELECTRONICS		A2
TM8000 400-530MHZ POWERSUPPLY		
IPN: 220-01697-10	ISSUE: B	VARIANT NUMBER: ?
FILE DATE: Tue Jun 07 15:19:00 2005		
ENGINEER: Craig McGlinchy	FILE NAME: 220_01697	SHEET NUMBER: 5 OF 9

REV/ISS	AMENDMENTS	DRAWN	CHKD	D. O.	APVD	DATE
1	2	3	4	5	6	7

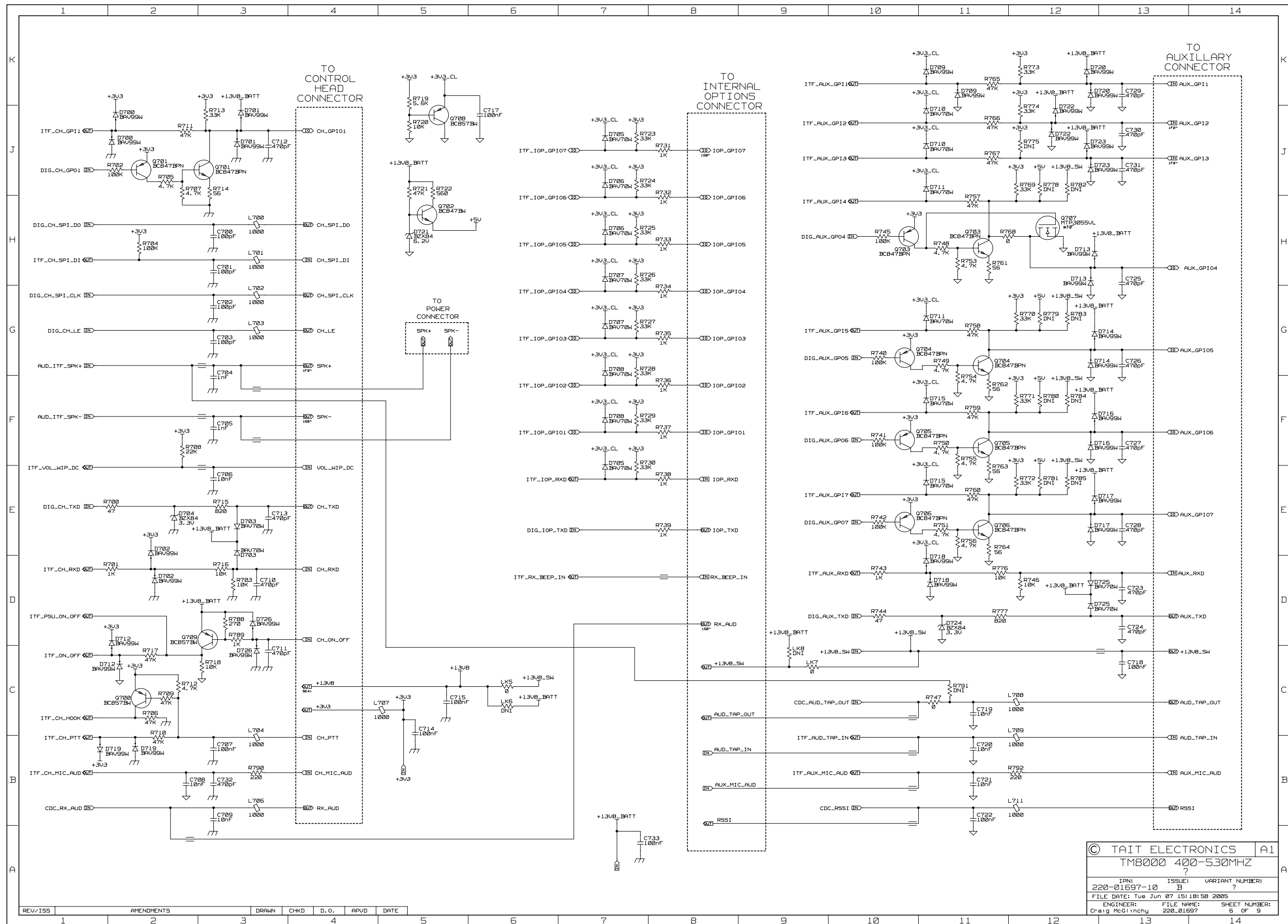

© TAIT ELECTRONICS		A1
TM8000 400-530MHZ		?
IPN: 220-01697-10	ISSUE: B	VARIANT NUMBER: ?
FILE DATE: Tue Jun 07 15:18:58 2005	ENGINEER: Craig McGlinchy	FILE NAME: 220_01697
		SHEET NUMBER: 6 of 9

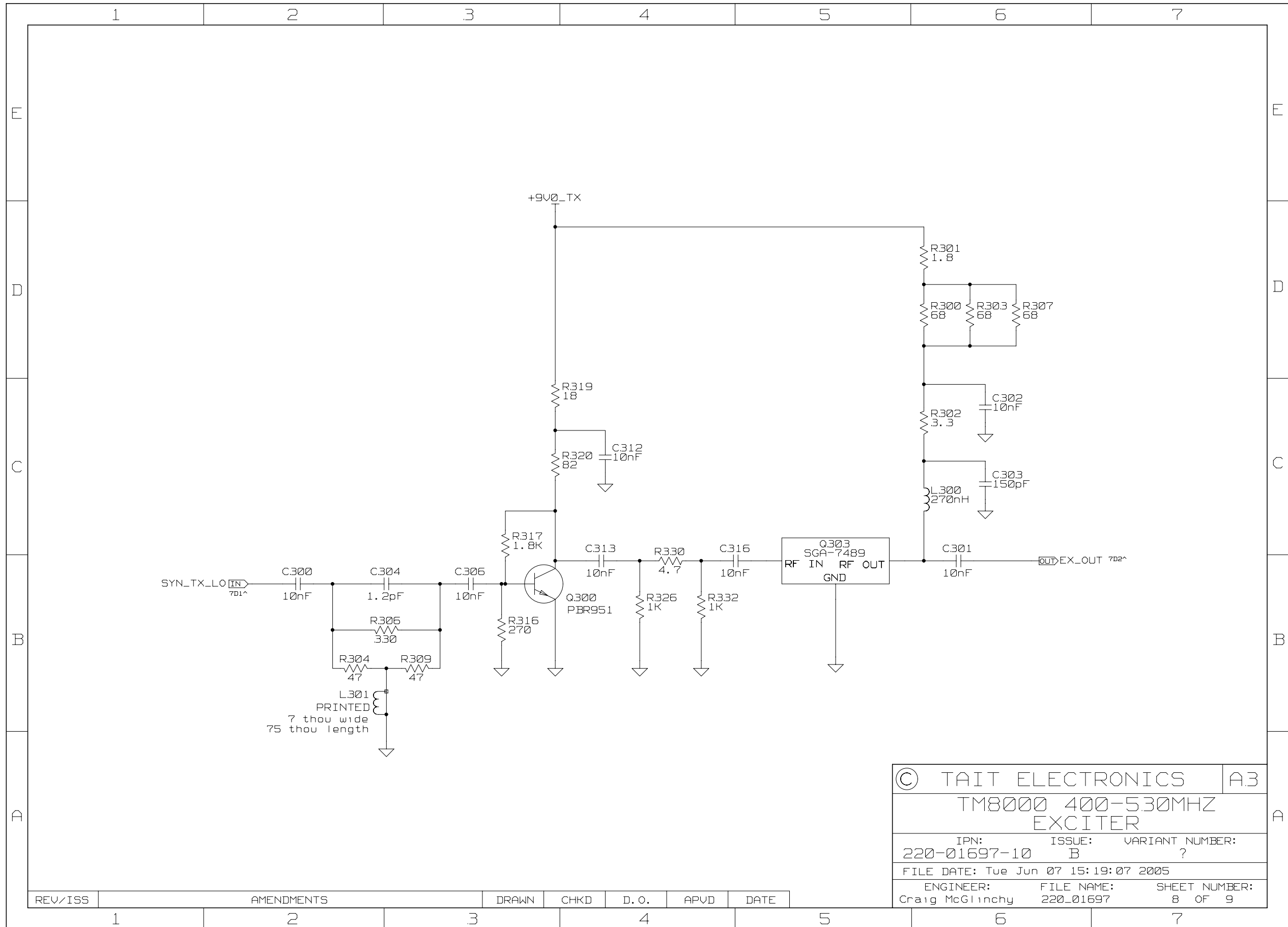

© TAIT ELECTRONICS		A3
TM8000 400-530MHZ EXCITER		
IPN: 220-01697-10	ISSUE: B	VARIANT NUMBER: ?
FILE DATE: Tue Jun 07 15:19:07 2005		
ENGINEER: Craig McGlinchy	FILE NAME: 220_01697	SHEET NUMBER: 8 OF 9

REV/ISS	AMENDMENTS	DRAWN	CHKD	D. O.	APVD	DATE
1						

